

Technical Data**GSV Screw Compressor Description****Description**

The ten models of the Gram GSV Rotary Screw Compressor units described herein range in capacity from 504 m³/h to 5620 m³/h at 2950 rpm. Standard units are designed for use on ammonia, halocarbon and hydrocarbon refrigerants at pressure ratios up to 26:1.

GSV Rotary Screw Compressor Units consist of the following major components: - Rotary Screw Compressor, oil pump and filter; drive coupling and guard; combined stop and check valve and filter on suction side. Combined stop and check valve on the discharge side; suction scale trap with strainer, and a three stage horizontal oil separator/reservoir. All components have been selected for maximum reliability and arranged to assure accessibility for service. The units are factory packaged, complete with wiring and piping.

Model GSV Compressor

Housing - All screw compressor castings are designed and tested to meet the requirements of common standard for 25.0 bar maximum discharge pressure. Castings are close grain ASTM-A 278 Class 40 cast iron to assure structural integrity, mechanical and thermal stability under all operating conditions.

Rotors - The rotors are machined from AISI-1137 steel forgings to the exacting tolerances of the latest SRM asymmetric profile. The four lobed male rotor is directly connected to the driver. The six lobed female rotor is driven by the male rotor on a thin oil film.

Bearings - Antifriction bearings are used for reduced power consumption, particularly at the higher pressure ratios. Cylindrical roller bearings are provided to handle the radial loads and the thrust loads are absorbed by angular contact ball bearings. In addition, thrust balance pistons are provided to reduce the thrust load and improve bearing life.

Shaft Seal - The compressor shaft seal is a metal bellow seal with a carbon rotating surface riding against a cast iron stationary seat. The seal is capable of sealing in proscribed pressure area.

Variable Volume Ratio Control - The Gram compressor includes a patented method of varying the internal volume ratio to match the system pressure ratio. With control of the internal volume ratio the power penalty associated with over or under compression is eliminated. The volume ratio control is achieved by the use of a slide stop which is a movable portion of the rotor housing that moves axially with the rotors to control the discharge port location. The slide stop is moved by hydraulic actuation of a control piston based on signals from the micro processor. The range of adjustability is from 2.2 Vi to 5.0 Vi.

Capacity Control - Capacity control is achieved by use of a movable slide valve. The slide valve moves axially with the rotors to provide fully modulating capacity control from 100% to approximately 10% of full load capacity. The slide valve is positioned automatically by hydraulic movement of its control piston based on time proportioned signals from the micro processor. When in the unloaded position, gas is by-passed back to suction through a recirculation slit before compression begins and any work is expended.

Lubrication System - The GSV compressor is designed specifically for operation without an oil pump. All oil required for main oil injection and lubrication is provided by positive gas differential pressure.

The standard high stage unit is furnished with a close-coupled positive displacement prelube pump for start-up only. For some low pressure differential applications full time or cycling lube pump will be required.

Technical Data

GSV Screw Compressor Description

Oil Separator/Reservoir - The oil separator is a horizontal, three stage design with integral sump. Two sight glasses are located in the reservoir section and one in the coalescing section. The separator is designed and constructed in accordance with common standards for a maximum design working pressure of 25.0 bar and supplied with by-pass valve from discharge to suction. Two heaters maintain oil temperature higher than surrounding during compressor shut-down.

Coalescent separator elements are provided for final gas/oil separation of particles down to less than 1 micron. The oil carry over to the refrigeration plant will normally be less than 10 PPM.

Oil is drained from the coalescer section and returned to the compressor suction during operation.

A float switch is installed in the first stage of the oil separator to detect a low oil level. If a low level occurs the float switch will shut the compressor down.

Oil Filter - All lubrication oil will pass through a 25 μ m absolute oil filter ($\beta_{25} \geq 75$ ISO 4572). Solid contaminants will be kept down to code 20/1 ϵ after ISO 4406. The filter is furnished with isolation stop valves and drain valve for ease of servicing.

Technical Data

GSV Screw Compressor Description

Liquid Injection Oil Cooling - The compressor oil is cooled by direct contact with refrigerant injected through one of two optimized port locations prior to the compressor discharge. Liquid feed arrangement includes a stop valve, strainer, solenoid valve, metering valve and stop valve. The metering valve will maintain temperature of oil returning to the compressor between 50°C and 70°C. At booster application liquid will be injected into the compressor after the compression has come to an end. This will not affect the capacity.

Water Cooled Oil Cooling - The optional water cooled oil cooler is a shell and tube design with oil on the shell side. The oil temperature is maintained at 50°C - 60°C. As optional an automatically water regulating valve sensing outlet oil temperature can be supplied.

Thermosyphon Oil Cooling - Maintains oil temperature 10°C - 20°C higher than condensing temperature. The optional thermosyphon cooler is a shell and tube design. The oil cooler is mounted on the unit with the oil piping connected. Refrigerant connections and controls are field installed.

Economizer - Increased refrigeration capacity with relatively low increase in brake horsepower can be achieved by the use of a Gram economizer system. The economizer consists of a shell and coil or shell and tube liquid subcooler with appropriate controls. Refrigerant vapor from the subcooler is piped to an optimized pressure port on the compressor.

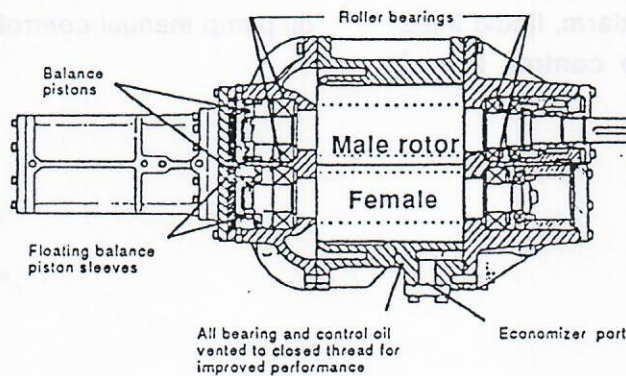
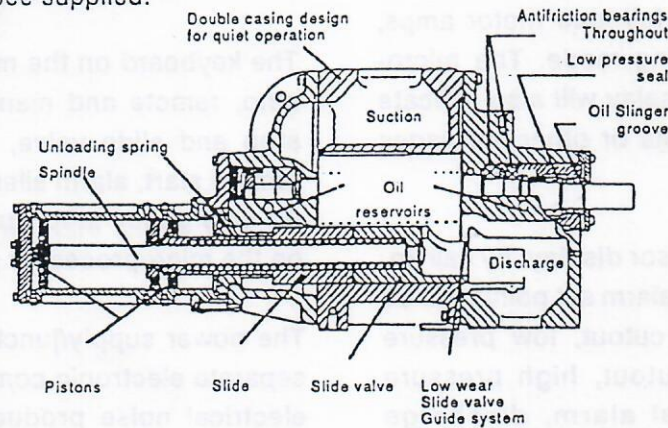

Technical Data**GSV Screw Compressor Description****Microprocessor Control Center**

The compressor control system is factory mounted, completely piped and wired with all the required safety and operating devices. The control system includes as standard microprocessor control panel and a separate power/supply junction box. All transducers are wired and piped into a common manifold with a rated housing.

The microprocessor panel is supplied with a display. Continuous display may indicate: suction pressure and temperature, discharge pressure and temperature, oil pressure and temperature, filter pressure drop, slide valve position and mode, volume ratio position and mode, pump on/off, percent of full load motor amps, and compressor operating mode. The microprocessor continuous display will also indicate that alarm condition exists or other messages as required.

Through the microprocessor display, by call up, the following control and alarm set points will be indicated: low pressure cutout, low pressure alarm, high pressure cutout, high pressure alarm, filter differential alarm, discharge temperature cutout, discharge temperature alarm, oil pressure cutout, oil pressure alarm, suction pressure control, high oil temperature cutout, high oil temperature alarm, liquid injection oil cooling temperature control, low oil

temperature cutout, low oil temperature alarm, oil heater temperature control, low oil level and motor load control.

The microprocessor panel provides annunciation to indicate the first cause of shutdown as well as prealarms to warn of potential shutdown conditions. The panel will also store the exact operation conditions at the time of any shutdown or trip, and these data may be recalled via the "freeze display".

Included in the microprocessor is time proportioning capacity control. This method of capacity control reduces hunting and provides a more stable capacity control.

The keyboard on the microprocessor includes: auto, remote and manual control of the slide stop and slide valve, compressor run, stop, remote start, alarm silence and display control. An emergency stop button is clearly mounted on the microprocessor panel.

The power supply/junction box is furnished to separate electronic components from heat and electrical noise producing components. This junction box supplies a single terminal point for customer wiring to the package and a convenient location for the elapsed time meter and oil pump manual control switch.

Technical Data

GSV/GSB Screw Compressor Design Limitations

Compressor type:	GSV 50	GSV 64	GSV/B 84	GSV/B 111	GSV/B 147	GSV/B 185
Rotor diameter [mm]	163.2	163.2	193	193	233	233
Length/diameter ratio	1.35	1.70	1.35	1.80	1.35	1.70
Theoretical displacement per drive shaft revolution [m ³ /rev. (ft ³ /rev)]	.0028511 (.100684)	.0035903 (.126788)	.0047155 (.166523)	.0062873 (.222029)	.0082971 (.293003)	.010448 (.368960)
Normal 50 Hz motor speed [rpm]	2950	2950	2950	2950	2950	2950
Displacement at above speed [m ³ /h (ft ³ /min)]	504.6 (297.0)	635.5 (374.0)	834.6 (491.2)	1112.9 (655.0)	1468.6 (864.4)	1849.3 (1088.5)
Special 60 Hz motor speed [rpm]	3550	3550	3550	3550	3550	3550
Displacement at above speed [m ³ /h (ft ³ /min)]	607.3 (357.2)	764.8 (449.9)	1004.3 (590.8)	1339.3 (669.3)	1767.3 (1039.6)	2225.4 (1309.1)
Max. Motor torque at start up. [Nm]	2600	2600	6000	6000	9000	9000
Max. power continuously at 50 Hz [kw]	160	160	315	315	500	500
Min./max. motor speed [rpm]	1800 / 4500					
Drive arrangement	Direct drive, coupling only.					
Volume ratio	GSB: Vi = 2.8; GSV: Variable from 2.2 to 5.0					
Capacity control	GSB: 3 steps: 100%, 75% and 50% of full load GSV: From 100% to 10% of full load, infinite adjustment					
Rotation of drive shaft	Clockwise facing the shaft end					
Maximum outlet pressure	pe = 25.0 bar (363 psig)					
Operating pressure limits	See data sheet 0.70.42					
Maximum differential pressure	Discharge pressure - suction pressure = max. 24.0 bar (348 psi)					
Minimum inlet temperature *	-60°C (-76°F)					
Maximum inlet temperature	93°C (199°F)					
Maximum temperature differential	Discharge temperature - suction temperature = max. 135°C (275°F)					
Maximum outlet temperature	120°C (248°F)					
Maximum oil supply temp. **	80°C (176°F)					
Minimum oil viscosity ***	Kinematic 10 cst					
Minimum oil pressure ****	The minimum requirement is: -oil pressure is more than the discharge pressure -1,5 bar, and -oil pressure is more than closed thread pressure + 3 bar. The delay time on cut-out is set to 3 minutes. Additionally, if there is a solenoid valve in the oil line, the minimum oil pressure is (closed thread pressure + 1 bar). Delay time 20 sec.. Alternatively you can use a flow switch. Delay time 20 sec. too.					
Maximum oil pressure	3,4 bar above discharge pressure					
Max. Shaft load, axial and radial	200 N					
Oil filtration	According to ISO 4572, B25 >75 and B 10 >7					
Solid contamination in oil	According to ISO 4406 Code 20/16					

- *) Minimum suction pressure can be lower, but the sensitive temperature to the compressor should meet the above specification. Minimum inlet pressure is 0.4 bar for high stage compressors.
If the unit is equipped with stop valve on suction side, the suction pressure has to be measured between the stop valve and the compressor.
- ***) Recommended oil from sheet 2.00.41/42 has only required viscosity when oil temperature is kept below 65°C.
Remember that oil viscosity will be reduced as refrigerant dissolves into the oil.
- *) Use level switch or flowmeter to ensure that the oil pressure transmitter/switch measures oil and not gas.

Technical Data

GSV/GSB Screw Compressor Operating Pressure Limits

Curves below show the operating pressure limits for speed at 2950 rpm. Do not use GSB at pressure ratios above 10 or discharge pressure above 15°C. Always use oil pump on GSB.

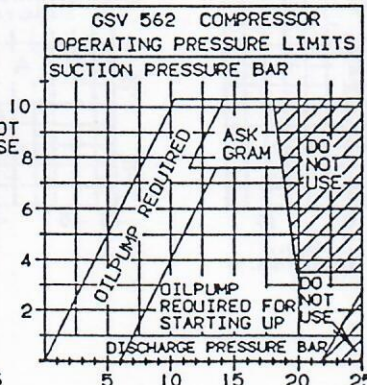
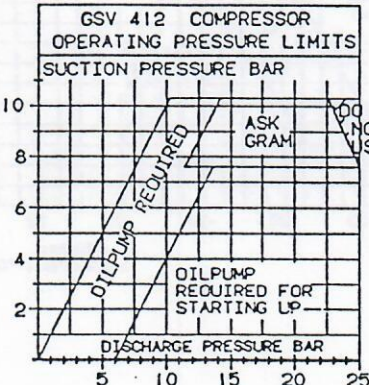
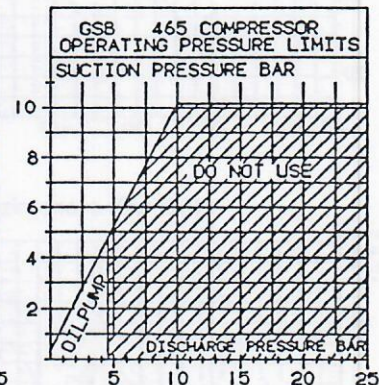
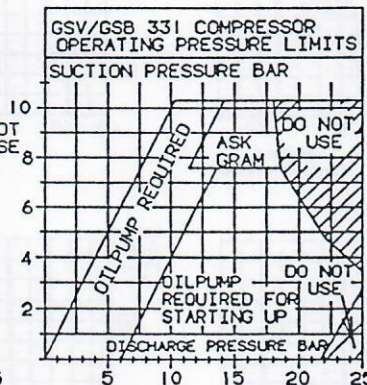
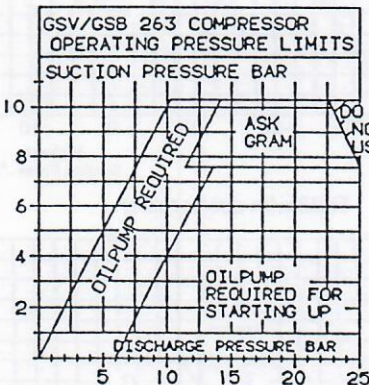
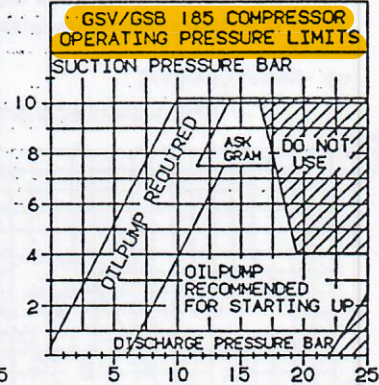
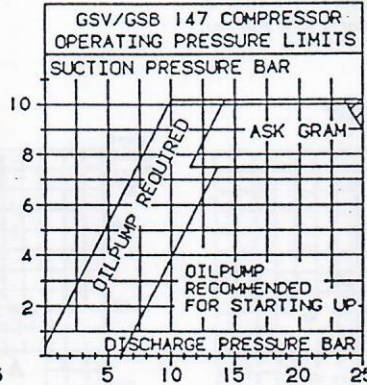
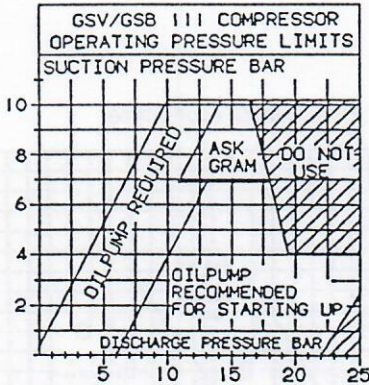
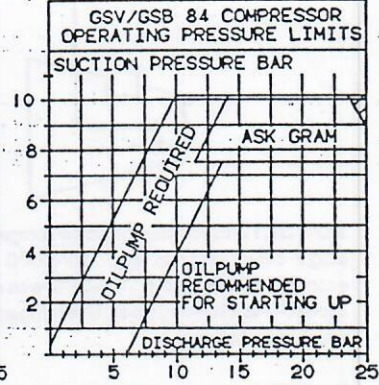
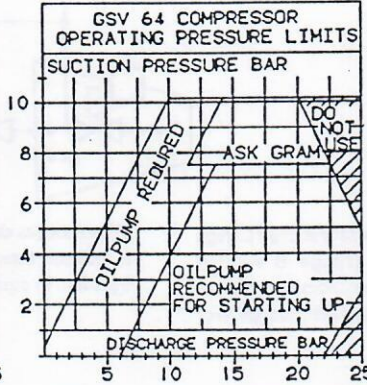
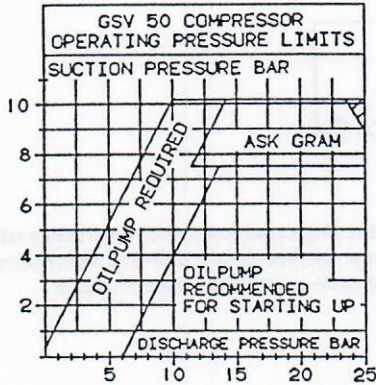

GRAM
772579072001024

Technical Data

GSV/GSB Screw Compressor Liquid Injection - Limitations

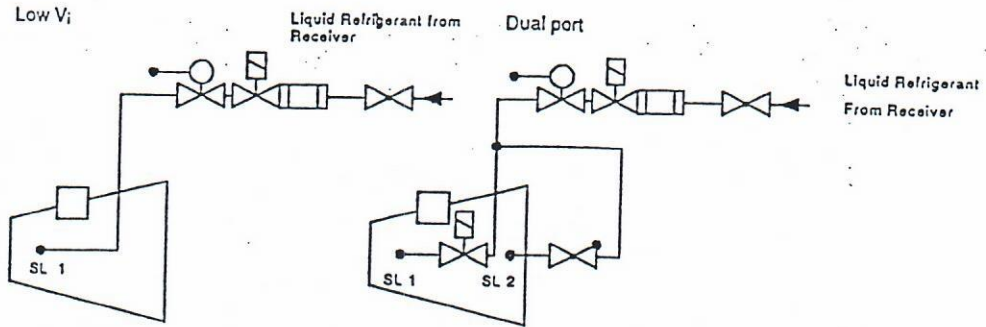

Port SL1 is used when the screw compressor is used as high stage compressor at e.g. $-10/+35^{\circ}\text{C}$ (range B without economizer). NB at e.g. $-10/+35^{\circ}\text{C}$ with economizer it is not allowed to use liquid injection. Use refrigerant thermosyphon or water cooled oil cooler.

When hot gas defrosting is used during which the pressure ratio is reduced, these pressure ratios should be used when choosing injection. In such cases an oil cooler is recommended.

Port SL2 is used when the screw compressor is used as booster compressor or when the compressor is, with dual port injection.
e.g. $-40/+35^{\circ}\text{C}$. (range A).

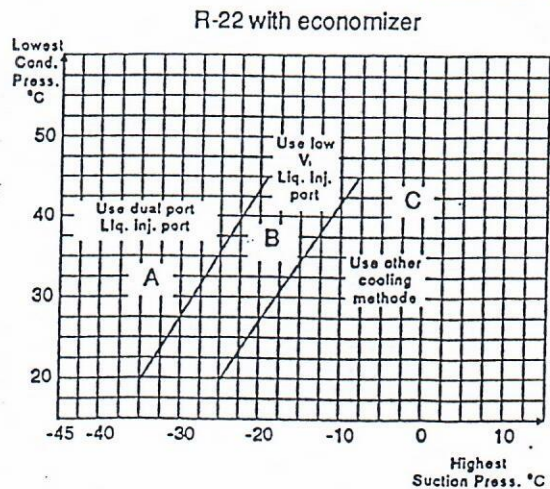
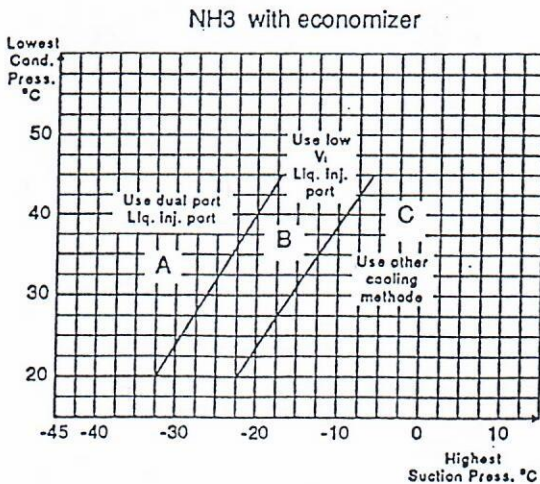
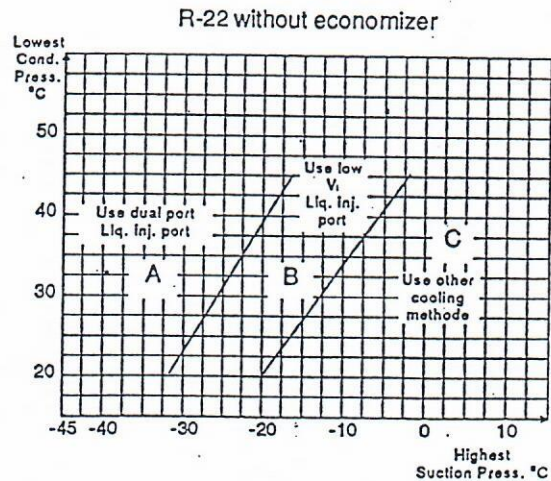
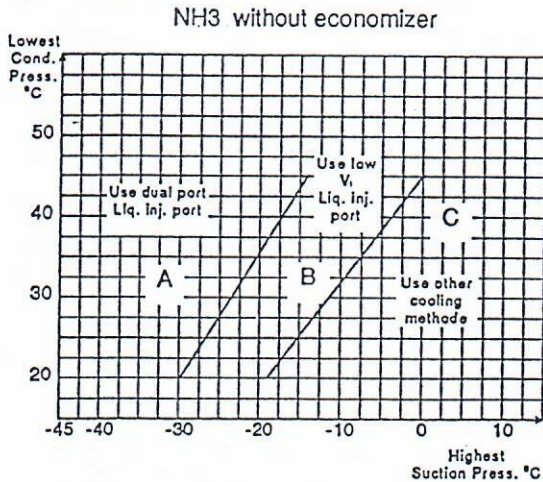

Technical Data

GSV 147 - 185 Screw Compressor Block. Dimensions

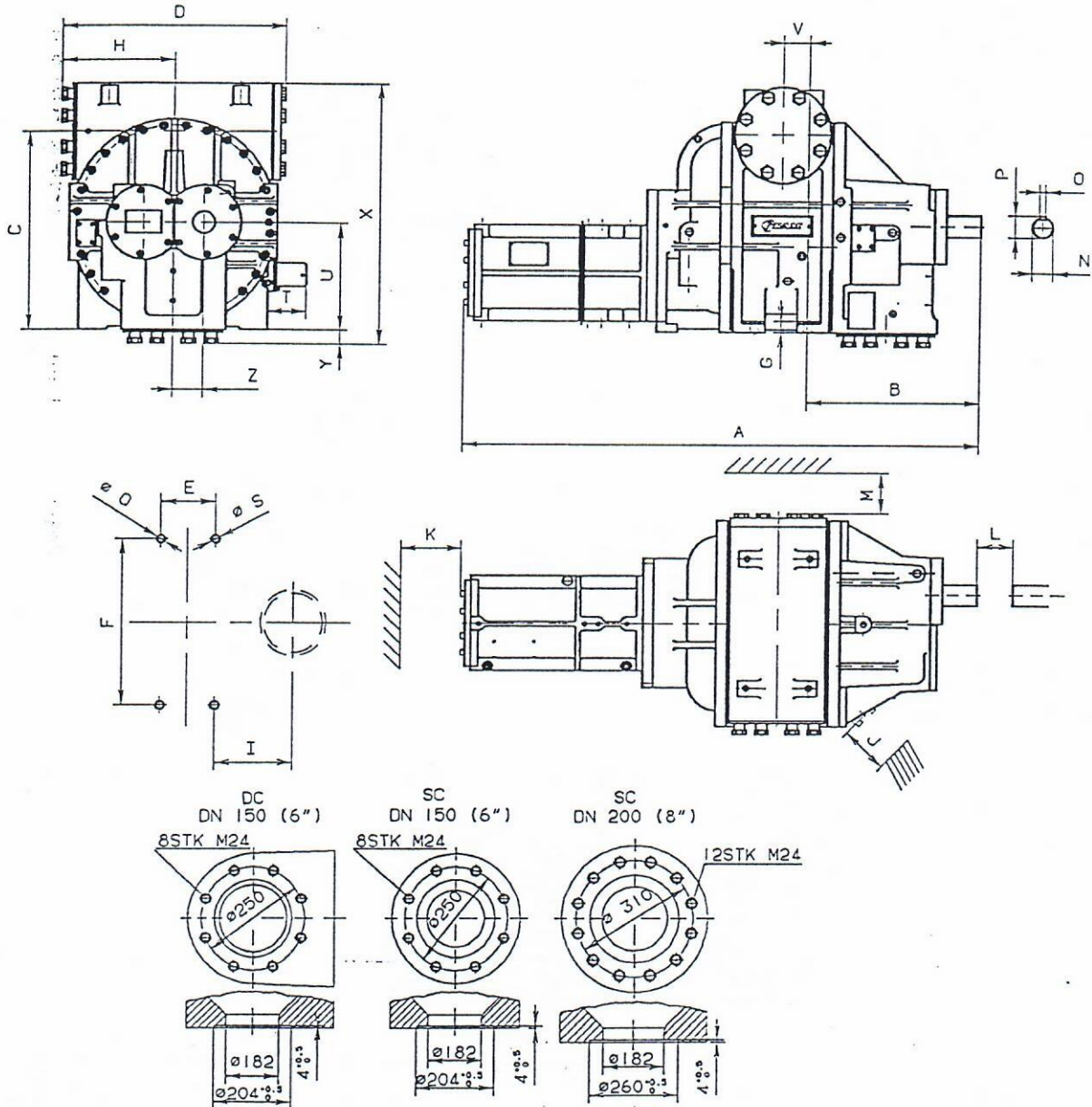

	A	B	C	D	E	F	G	H	I	J	K	L	M	N
GSV 147	1600	533	606	684	165	510	35	343	243	132	760	110	554	63.5
GSV 185	1682	533	647	684	247	510	35	343	243	132	760	110	554	63.5

	O	P	Q	S	T	U	V	X	Y	Z	SC *	DC *
GSV 147	18	67.5	∅25	∅25	119	327	82.5	799.0	43	41.4	DN 150 (6")	DN 150 (6")
GSV 185	18	67.5	∅25	∅25	119	327	123.3	877.5	43	91.4	DN 200 (8")	DN 150 (6")

* DIN 2635/2512 ISO 7005

Technical Data

GSV 84 - 111 - 147 - 185 Screw Compressor Block. Port Description

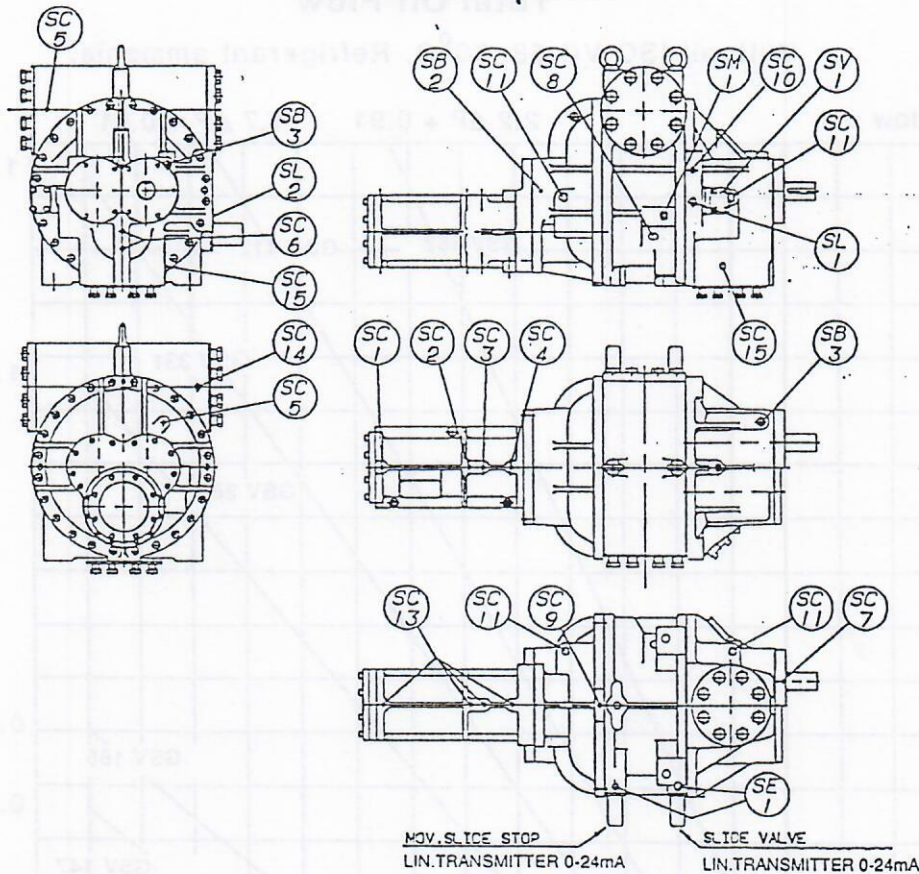

Symbol	Port Description	Size
SC 1	Slidevalve-unload	Rc 1/4"
SC 2	Slidevalve-load	Rc 1/4"
SC 3	Moveable slide stop-increase Vt	Rc 1/4"
SC 4	Moveable slide stop-decrease Vt	Rc 1/4"
SC 5	Inlet pressure	Rc 1/4"
SC 6	Discharge pressure	Rc 1/4"
SC 7	Seal weepage	Rc 1/4"
SC 8	Oildrain connection (Closed Thread)	Rc 1"
SC 9	Inlet oildrain	Rc 1/4"
SC 10	Discharge bearings prelube (Optional)	Rc 3/4"
SC 11	Oildrain connection (Optional)	Rc 3/4"
SC 13	Oildrain cylinder	Rc 1/4"
SC 14	Oilfill valve	Rc 1/2"
SC 15	Outlet pressure (For sensor bulb or Pt-100)	Rc 1/2"
SB 2	Inlet bearing blance piston	Rc 1/4"
SB 3	Discharge bearings-seal	Rc 3/4"
SE 1	Electrical connector	Rc 1/2"
SM 1	Main oil injection	Rc 3/4"
SV 1	Vapor injection tongue-groove *	ø38
SL 1	Low Vi liquid injection	Rc 3/4"
SL 2	High Vi liquid injection	Rc 3/4"

* With economizer connection use Danfoss flange No. 027N2340 Gram art. No. 61-021-0011.

Technical Data

GSV Screw Compressor

Total Oil Flow

With oil ISO VG 68, 50°C. Refrigerant ammonia.

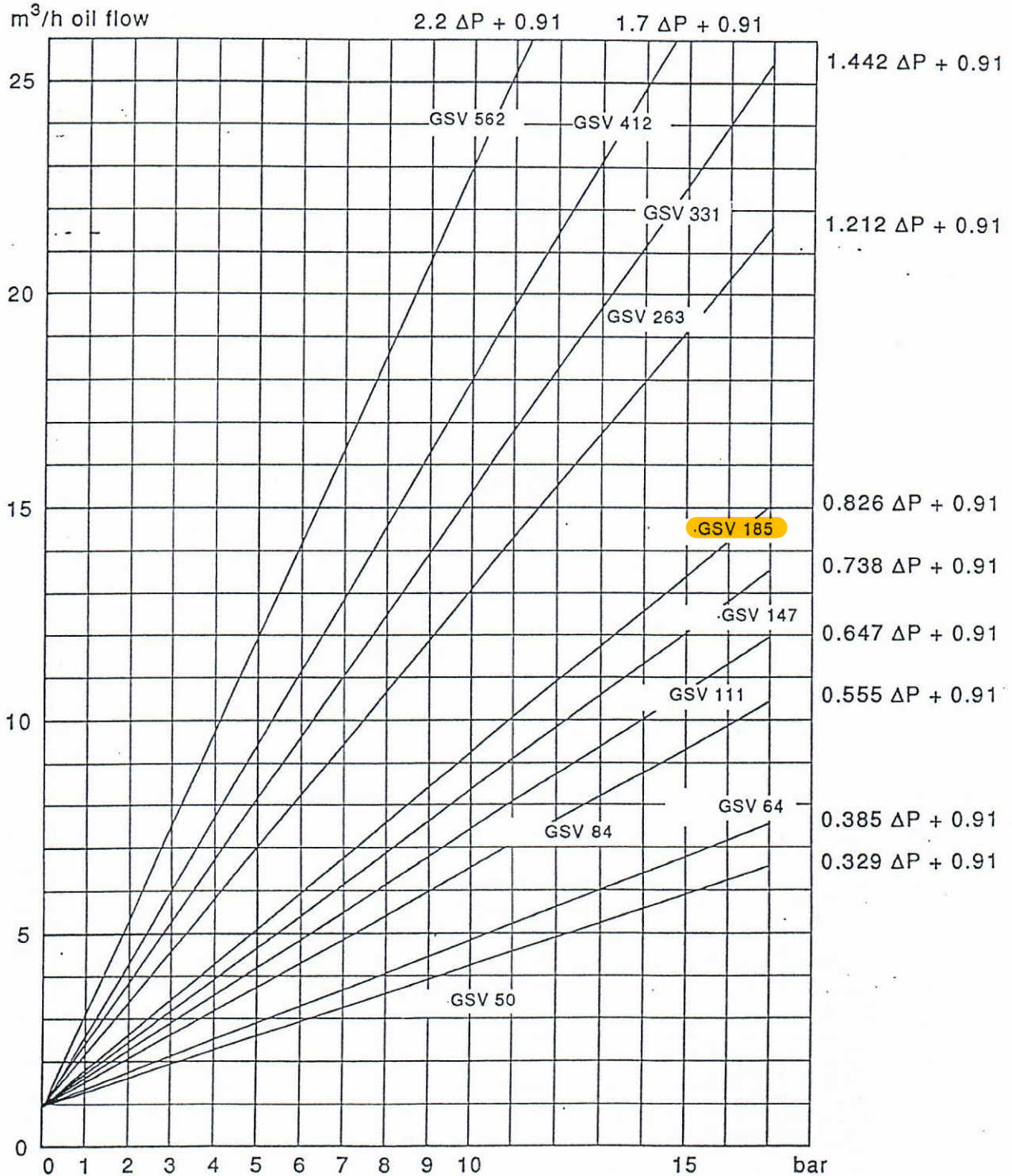

ΔP: Oil pressure minus suction pressure (P_{oil} - P_s) bar.

Technical Data

GSV/GSB Screw Compressor
Bearing Oil Flow (Port SB2 and SB3)
 With Oil ISO VG 68, 50°C. Refrigerant ammonia.

GSV/GSB	Oil flow m ³ /h
50 - 64	0.176 ΔP + 0.45
84 - 111	0.220 ΔP + 0.45
147 - 185	0.264 ΔP + 0.45
263 - 331 - 465	0.329 ΔP + 0.45
412 - 562	0.365 ΔP + 0.45

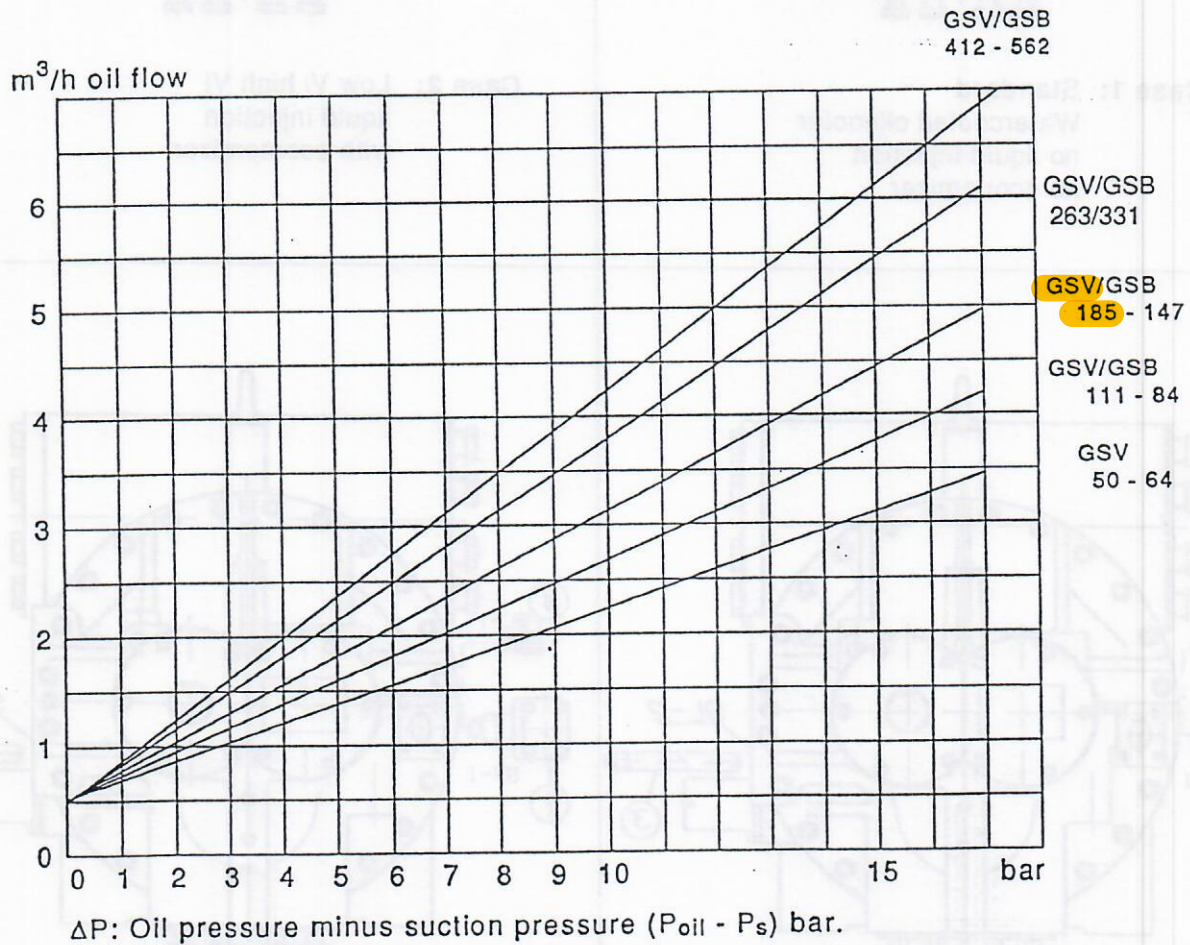

Technical Data

**GSV 50-185 Screw Compressor Block.
Optional Connections**

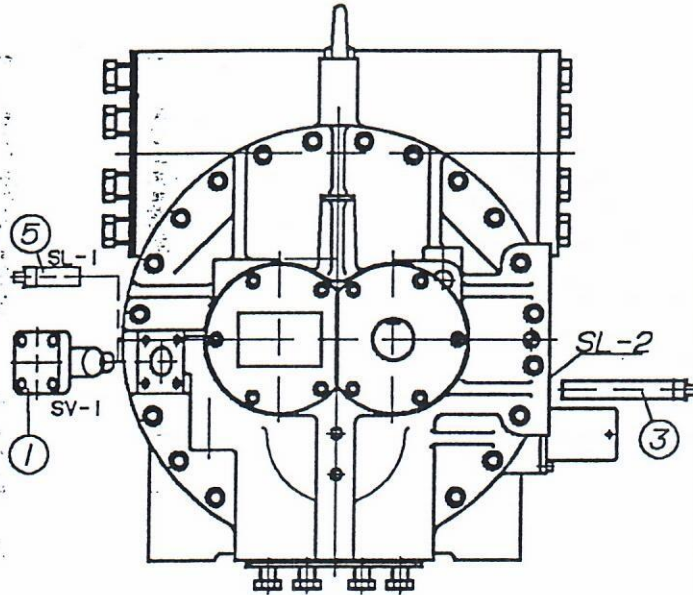

Case 1: Standard
Watercooled oilcooler
no liquid injection
no economizer

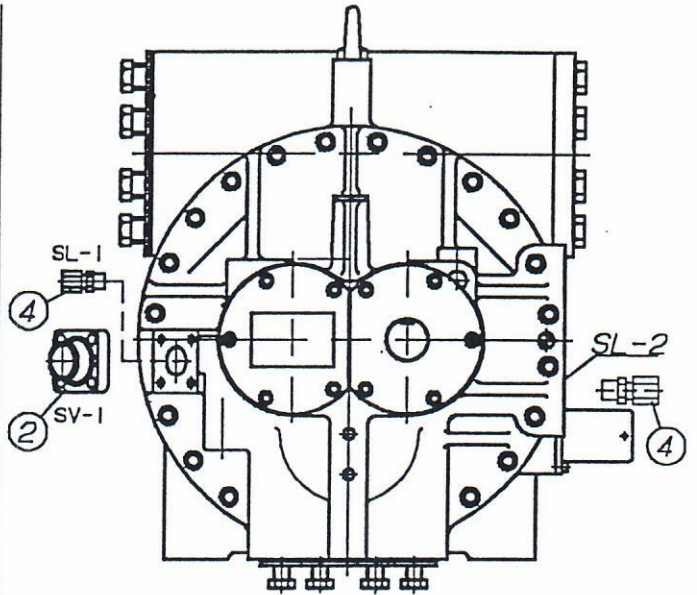

Case 2: Low Vi high Vi
liquid injection
with economizer

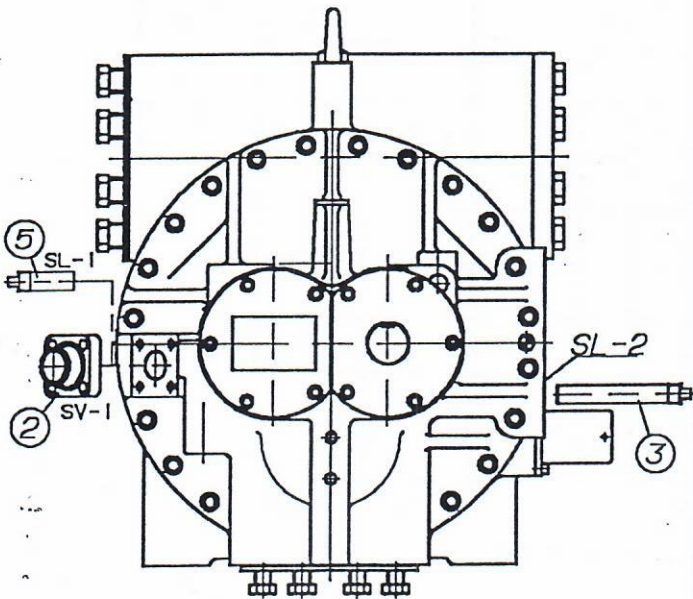

Case 3: Watercooled oilcooler
no liquid injection
with economizer

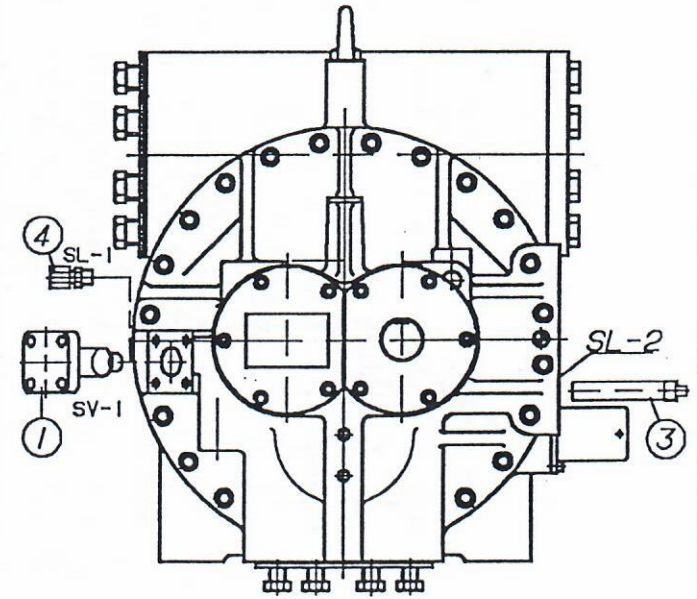

Case 4: Low Vi liquid injection only

All information given above is subject to change without notice.

Technical Data

GSV 50-185 Screw Compressor Block. Optional Connections

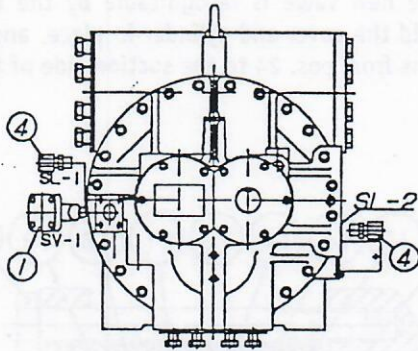

Case 5: Low Vi and high Vi
Liquid injection
no economizer

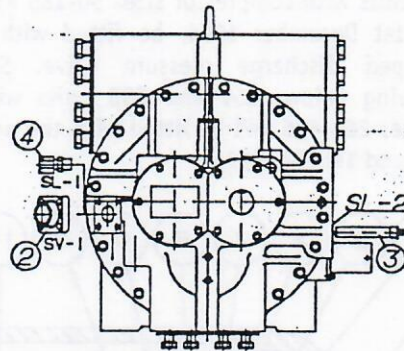



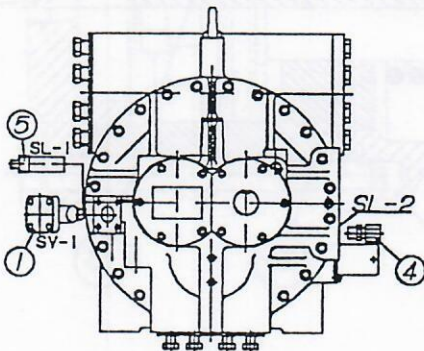

Case 6: Low Vi liquid injection
with economizer

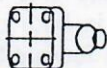

Case 7: High Vi liquid injection
no economizer

Port description

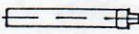
SV-1	Economizer
SL-1	Low Vi liquid injection
SL-2	High Vi liquid injection

Item			GSV	Gram nr.
1		Economizer plug	50-64 84-111 147-185	77-163-2040 77-193-2040 77-193-2040
2		Economizer flange (welding connection $\varnothing 48,3$)	50-64 84-111 147-185	61-021-0011
3		High Vi plug (Rc 3/4")	50-64 84-111 147-185	77-163-2044 77-193-2044 77-233-2044
4		Pipe fittings (Rc 3/4") (pipe size $\varnothing 22$)	50-64 84-111 147-185	46-085-2125
5		Low Vi plug (Rc 3/4")	50-64 85-111 147-185	77-193-2045

New Discharge Pressure Valve GVD for GSV and GSB Compressors

GSV and GSB units with compressor sizes 50-185 will, from around 1st December 1994, be fitted with a newly developed discharge pressure valve. See sectional drawing below. GSV and GSB units with compressor sizes 263-465 will be fitted with the new valve from around 1st May 1995.

The new valve is recognisable by the long bolts that hold the cover and cylinder in place, and the tube that runs from pos. 24 to the suction side of the compressor.

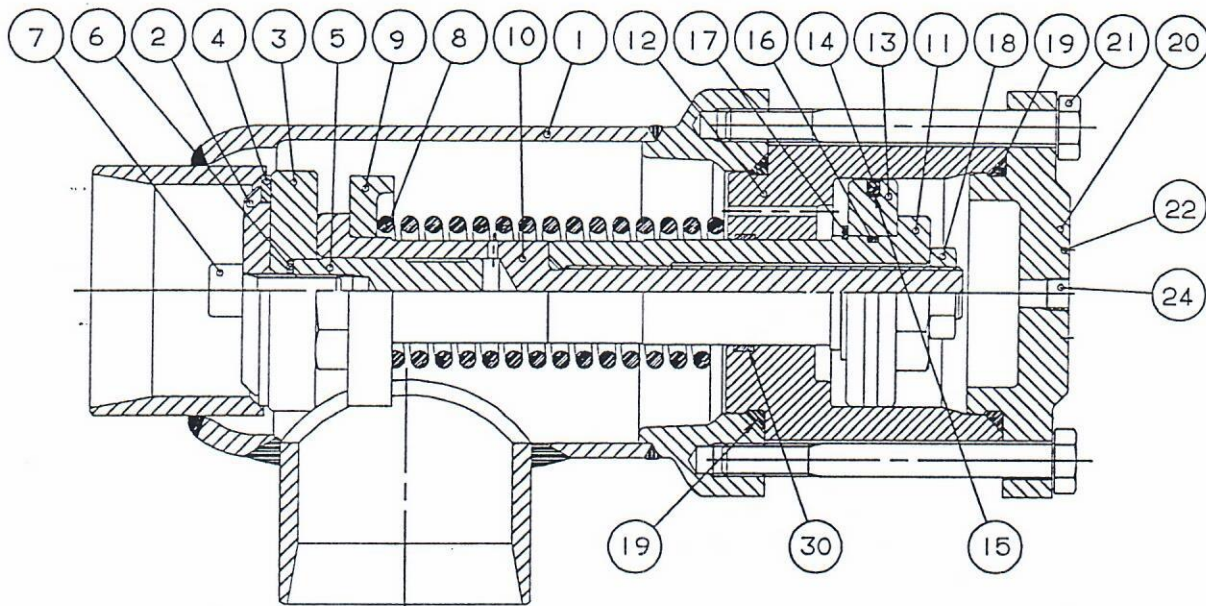

The new GVD valve is force-controlled so that when pressure in the oil separator becomes 2 bar higher than the suction pressure, the spring is compressed and the valve opens. In low-pressure units (boosters), the spring requires a differential pressure of 1 bar for the valve to open. The round label on the valve end cover indicates which spring is fitted.

The new valve offers four significant advantages in comparison with traditional non-return valves:

1. no chatter at part-load
2. no pressure drop because of spring force
3. high closing force on the cone during standstill, even without differential pressure across the valve
4. fast build-up of oil pressure in oil separator during start-up.

re 1/2: Since the valve is force-controlled, the flow must not overcome the spring force, i.e. the spring is

compressed by the difference between the pressure in the oil separator and the suction pressure.

re 3: The closing force is about ten times higher in GVD than in traditional non-return valves.

re 4: Especially on units without oil pump, it can be difficult, when starting to build up oil pressure in the oil separator, to drive oil forward to the compressor. For example, if there is no pressure in the condenser when the unit is started because pressure must be built up in both condenser and oil separator before oil is driven forward to the compressor.

Since the new GVD valve cannot be shut off manually, a GV shut-off valve will also be fitted on the units. This provides the possibility of servicing the new valve, whereas on earlier units the non-return valve could not be serviced because it was a combined stop and non-return valve.

All information given above is subject to change without notice

The GVD valve is to be connected as shown below
(with P+I diagram symbols)

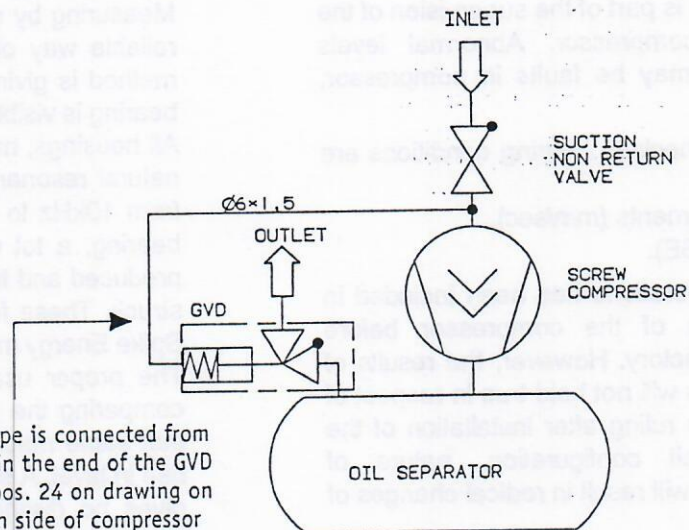

This Ø6x1,5mm pipe is connected from the Rc 1/8" port in the end of the GVD valve (shown as pos. 24 on drawing on page 1) to suction side of compressor (between suction non-return valve and compressor).

NOTE:

The GVD valve cannot be used on compressor units where the non-return valve is placed between compressor and oil separator instead of on the suction side of the compressor. The reason for this is that the GVD valve needs to have the Ø6x1,5 mm pipe connected to a point on the compressor unit, where the pressure is low during running and high during standstill.

The GVD valve must be mounted so that the cylinder is placed horizontally. This will ensure correct function of the valve and make service more friendly. Please remember to dismantle the valve when welding is made.

Following part numbers can be used when ordering the valve separately:

GVD for high pressure duty	Part no.	GVD for low pressure duty	Part no.
DN 65	77-257-0570	DN 65	77-257-0571
DN 80	77-257-0572	DN 80	77-257-0573
DN 100	77-257-0574	DN 100	77-257-0575
DN 125	77-257-0576	DN 125	77-257-0577
DN 150	77-257-0578	DN 150	77-257-0579

Technical Data**Screw Compressor Type GSV/GSB
Vibration Measuring****Introduction**

Vibration measuring is part of the supervision of the condition of the compressor. Abnormal levels indicate that there may be faults in compressor, drive or motor.

Here two ways of checking bearing conditions are mentioned:

1. Velocity measurements (mm/sec).
2. Spike Energy (g SE).

The measuring of vibrations has been included in the general testing of the compressor before despatch from the factory. However, the results of these measurements will not hold true in respect of the actual conditions ruling after installation of the compressor as unit configuration, nature of operation and set up will result in radical changes of the vibration level.

Immediately following the initial start-up and insulation of piping systems etc. to prevent vibration, a measuring of the vibration level should be carried through and the results of this measurement will now serve as future reference values for measurements made according to the schedule below.

Measuring of velocity

Measuring by method 1) mentioned above, vibration levels should be below 6 mm/sec (rms). If the values are above this, vibration measuring should be taken more often than recommended to follow the development of the vibration level. At values above 12 mm/sec (rms) the compressor needs an overhaul.

The values (limits) given here are typical values. As vibration level is depending on the installation of the compressor, the development of the vibration level tells more about the bearing conditions than the actual value itself. An accelerating increase in level indicates that it is time to give the compressor an overhaul.

sheet 2 40 56 has earlier given the actual frequencies ruling with failures in bearing innerrace, outrace and ball or roller. These frequencies could point out the bearing with a failure. As measuring of all these frequencies needs very special and expensive equipment we have removed these values. Furthermore, if the compressor is to be opened, all bearings are to be changed anyway.

All information given above is subject to change without notice.

Spike Energy

Measuring by method 2), Spike Energy, is a more reliable way of detecting bearing failures, as the method is giving a warning before the failure of a bearing is visible.

All housings, machine structure and bearings have natural resonant frequencies typically in the range from 10kHz to 50kHz. At any minor damage of a bearing, a lot of high-frequency energy is being produced and the bearing will ring like a bell being struck. These frequencies are detectable by using Spike Energy measuring equipment.

The proper usage is in trending the levels (i.e., comparing the readings with a baseline taken for that same machine), and watching for the relative rise in level. A single Spike Energy reading by itself gives no distinct information. Though experience has shown, that following values can be used for indication of the bearing conditions:

- Below 0.5 gSE Bearings are OK.
Above 0.5 gSE Measurements more often than recommended are to be made.
Above 2.0 gSE An overhaul is needed.

The best solution is to make measurements with both methods. Gram offers equipment which is able to make both types of measurements.

Measuring procedure

The recommended schedule for making measurements is:

50h - 1,000h - 5,000h - 10,000h - 15,000h etc.

If measurements are made from the beginning the paint is not to be scraped of at the measuring points. If measurements are made on an "old" compressor (without reference measurements) it is recommended to scrape of the paint and use the values above to indicate the bearing conditions.

1. The measuring points are to be marked with the numbers shown on sheet 2 40 56.
2. The compressor control is put into manual operation and some reasonable values for Vi and capacity are entered. These values as well as the other running conditions should be the same at future measurements.
3. Make measurements for both Spike Energy and velocity and note the values in the operating log.
4. After measurements are made, the compressor control is put into normal operation mode....

Technical Data

Screw Compressor Type GSV/GSB Vibration Measuring

The measuring points are indicated on the drawings below.

Date _____

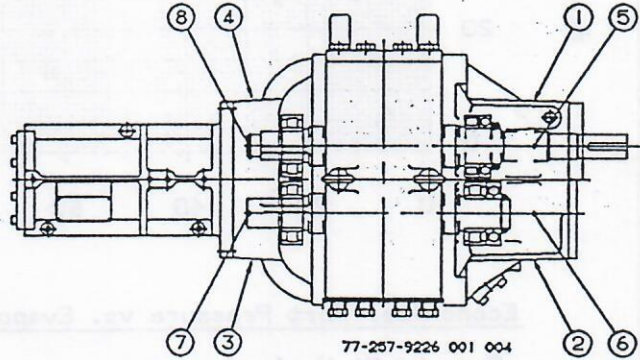
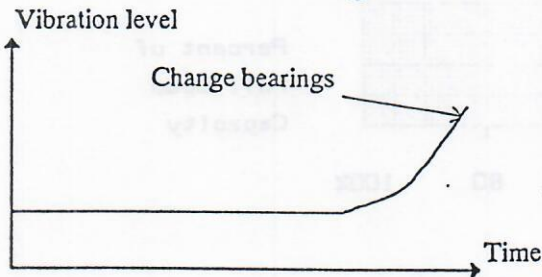
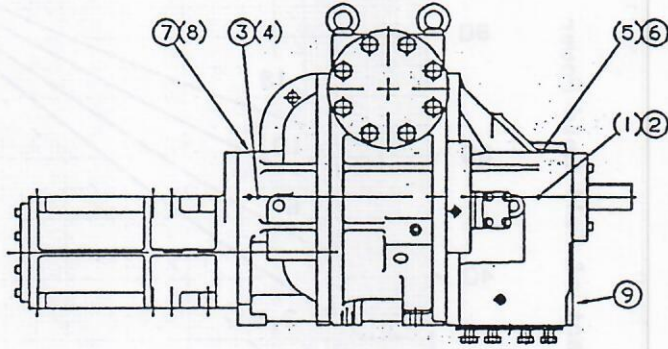
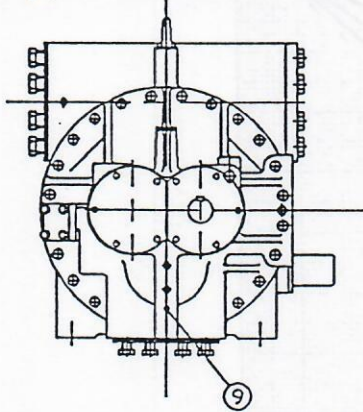

This sheet can be used for logging data:

Customer _____ Order no. _____

Plant designation _____ Compressor type _____

Compr. part/serial no _____ Refrigerant _____

Running time _____ h P_{DISCHARGE} _____ bar P_{SUCTION} _____ °C Output _____ % Vi _____ Ampere _____ %

Spike Energy (g SE) Measuring point no.

1 _____ 2 _____ 3 _____ 4 _____ 5 _____ 6 _____ 7 _____ 8 _____ 9 _____

Velocity (mm/sec) Measuring point no.

1 _____ 2 _____ 3 _____ 4 _____ 5 _____ 6 _____ 7 _____ 8 _____ 9 _____

Measurements can also be made on the motor:

	Drive End			Non-drive end	
	g SE	mm/sec		g SE	mm/sec
Axial	_____	_____	Axial	_____	_____
Radial, horizontal	_____	_____	Radial, horizontal	_____	_____
Radial, vertical	_____	_____	Radial, vertical	_____	_____

Technical Data

GSV NH3

Part Load Performance vs. Compression Ratio

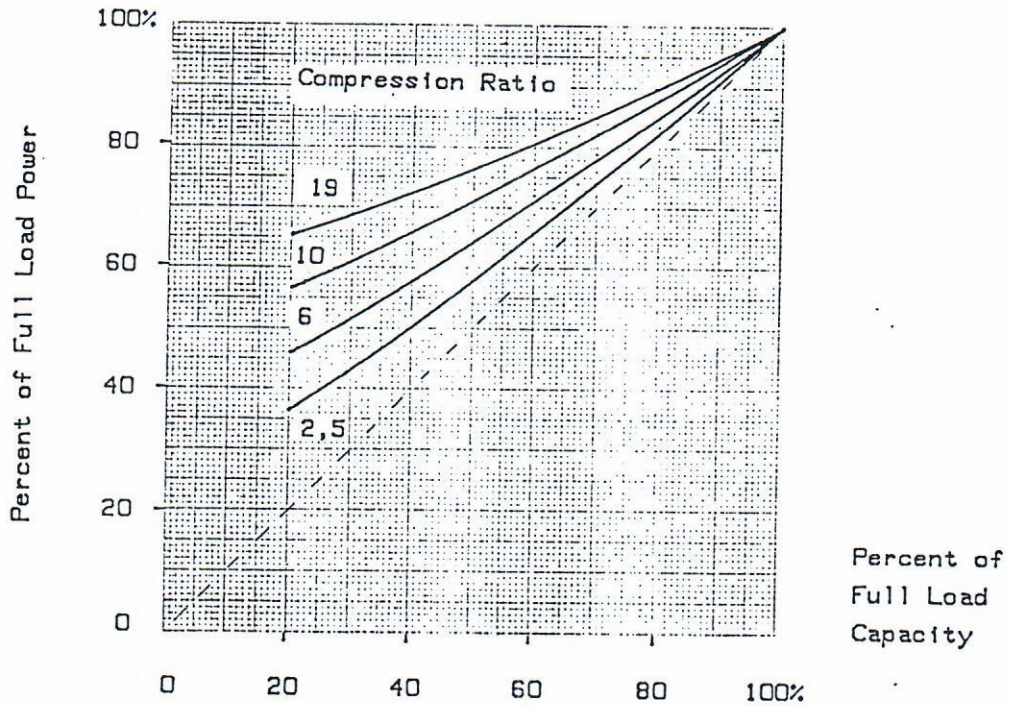

Economizer Port Pressure vs. Evaporation Temperature

Remark: At No load.

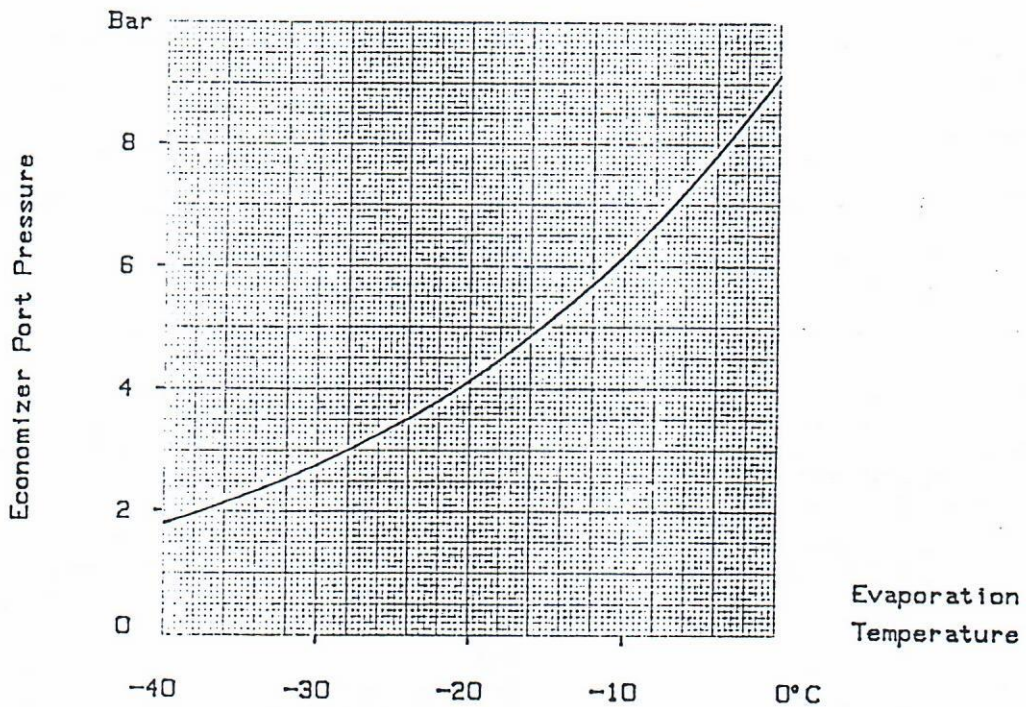

Technical Data

Screw Compressor Unit Type GSV
Sound Pressure Level (SPL)

For a GSV screw compressor unit at average operating conditions (running speed 2950 rpm and discharge pressure 35°C), the airborne sound pressure level in decibel will be as shown below.

Measurements are taken in accordance with ISO 3744 and the distance L is 2.0 m, taken in a free field and on a plane surface.

Octave Band Center Frequency Hz	Sound Pressure Level, (dB) GSV 50-64	Sound Pressure Level, (dB) GSV 84-111	Sound Pressure Level, (dB) GSV 147-185	Sound Pressure Level, (dB) GSV 263-331	Sound Pressure Level, (dB) GSV 412-562
62,5	74	74	74	74	73
125,0	72	73	75	78	76
250,0	78	81	84	86	78
500,0	81	81	82	88	86
1000,0	79	79	81	81	83
2000,0	72	72	73	75	82
4000,0	65	65	67	67	80
8000,0	62	62	65	65	79
Average dB(A)	82	83	84	87	87

Corrections:

Re: 20 μpascal (Threshold of hearing).

Correction for measuring distance L ≠ 2m:

$$\text{Correction} = 10 * \log\left(\frac{2}{4 * \pi * L^2}\right) + 14$$

Correction of the average value dB(A) at operating conditions different from above.

Actual average value:

$$dB(A)_x = dB(A)_s + 0,15 * (P_x - 35) + 0,004 * (n_x - 2950)$$

Where $dB(A)_s$ = average value at standard operating conditions, see table

P_x = actual discharge pressure, °C
 n_x = actual running speed, rpm

Notes:

1. Additional equipment, such as motors, heat exchangers, pressure vessels, piping, and valves may increase noise levels measured at the installation. The above noise levels reflect the noise contribution from a specific type of oil separators designed for a range of operating conditions. Due to the unpredictable nature of gas pulsations, and the wide range of possible application of this type of equipment, actual levels achieved in a plant may be higher or lower than indicated above.
2. The acoustic nature of the surroundings in which a unit is mounted and located may alter the characteristic and level of noise. Such conditions are out of our control.

GSV Screw Compressor Unit Dimensions.

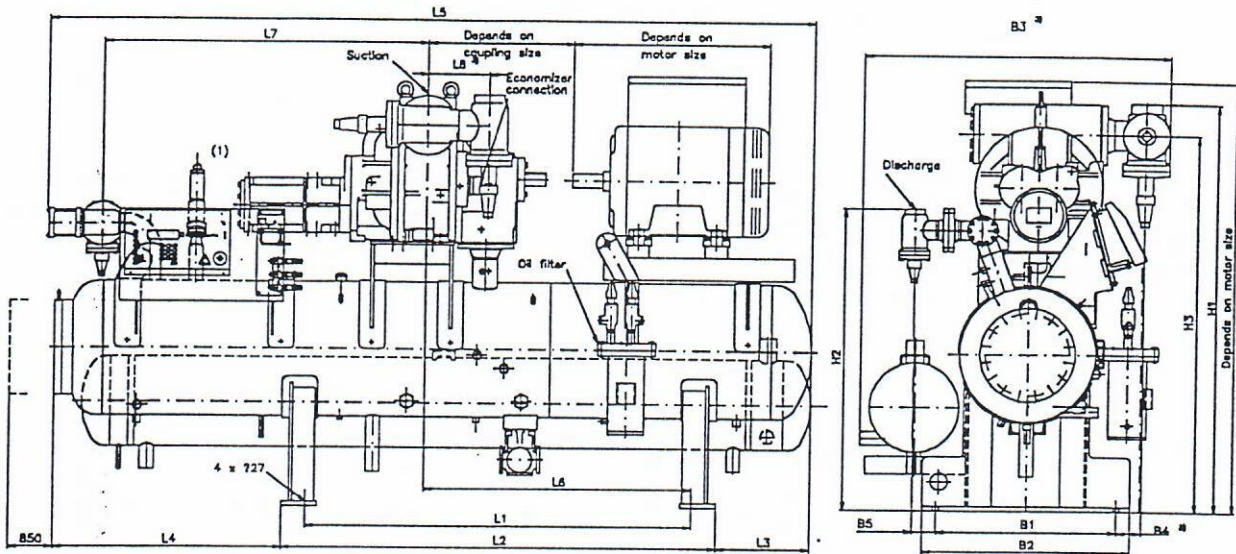

		GSV 50	GSV 64	GSV 84	GSV 111	GSV 147	GSV 185
L1	mm	1600	1600	1750	1750	1900	1900
L2	mm	1820	1820	1970	1970	2160	2160
L3	mm	545	545	420	420	650	650
L4	mm	980	980	1010	1010	1480	1480
L5	mm	3400	3400	3430	3430	4400	4400
L6	mm	935	965	1220	1265	1425	1465
L7	mm	1605	1575	1440	1395	1920	1885
L8	mm	240	280	280	360	360	500
B1	mm	800	800	800	800	1000	1000
B2	mm	920	920	920	920	1120	1120
B3 (3)	mm	1230	1325	1355	1470	1618	1758
B4	mm	45	105	110	155	93	168
B5	mm	75	75	110	110	115	115
H1	mm	1685	1725	1855	1910	2175	2285
H2	mm	1260	1260	1370	1370	1630	1630
H3	mm	1565	1585	1715	1730	1995	2035
Suction	mm	DN 100	DN 125	DN 125	DN 150	DN 150	DN 200
Discharge	mm	DN 65	DN 65	DN 80	DN 80	DN 100	DN 100
Diameter oil sep.	mm	500	500	600	600	750	750
Oil charge sep.	mm	210	210	325	325	600	600
Weight less motor/oil	kg	2200	2400	2700	2900	4500	4500
Shipping volumen max.	m ³	7.6	7.6	8.4	8.4	13.9	13.9

(1) See Design Data page 2.70.101 and 2.70.102 for connection of bypass valve.

(2) Dimension of oil cooler, see page 2.42.33 or 2.42.34

All dimensions are subject to confirmation.

Technical Data

GSV/GSB Screw Compressor Motor Selection and Starting Torque

Motors must be sized adequate for all expected operating conditions since start up, pull down and load variations quite often require significantly more horsepower than nominal design.

Motor starting torque capacity must also be considered, especially when another than across-the-line start is employed. Motor starting and pull-up-torque must be at least 20% greater

than compressor requirements at maximum expected start-up conditions. Refer to the torque data below.

Note: Motor starting torque varies considerably with various manufacturers -obtain specific torque data for the motor being used.

Speed Vs Torque Fully unloaded.

Example:

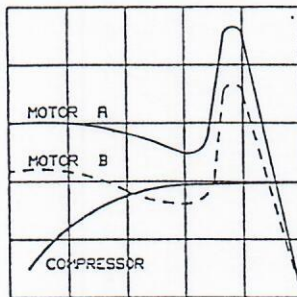

Motor A will start the compressor, B will not.

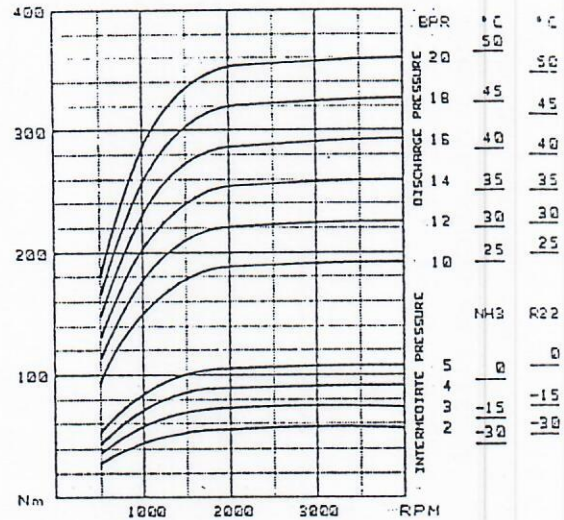

Model no. GSV/GSB/GSF	Starting Torque Multiplier	Break-away Torque Nm	Inertia I kgm ²
GSV 50	0.46	9.5	0.13
GSV 64	0.58	9.5	0.15
GSV 84	0.75	13.6	0.30
GSB 84	1.50	13.6	0.30
GSV 111	1.00	13.6	0.34
GSB 111	2.00	13.6	0.34
GSV 147	1.27	19.0	0.59
GSB 147	2.64	19.0	0.59
GSV 185	1.60	19.0	0.72
GSB 185	3.32	19.0	0.72
GSV 263	2.28	27.2	1.48
GSB 263	4.72	27.2	1.48
GSV 331	2.87	27.2	1.81
GSB 331	5.96	27.2	1.81
GSV 412	3.72	33.9	4.33
GSB 465	8.10	31.2	2.44
GSV 562	5.10	33.9	4.92

Remark: Flywheel effect $GD^2 = 4 \times I$ with I in kgm^2 and GD^2 in kpm^2

Starting Torque for Any Specific Compressor.
Multiply starting torque multiplier by starting torque value from curves at 100% of normal running speed. Calculation example:

GSV 185, NH₃ at 2950 RPM and 31°C discharge pressure (≈12 bar)

starting torque multiplier GSV 185 = 1.60

starting torque at 12 bar = 225 Nm.

GSV 185 starting torque = 1.60 x 225 = **360 Nm**

Motor/Compressor Torque:

Assure that the motor starting and minimum pull-

up torque capabilities will exceed the compressor requirements at the anticipated condition that will be experienced during normal starting (see example).

Note: Wye-delta and autotransformer (reduced voltage) motor starting methods drastically affect the starting torque available from motors as indicated.

Across-the-line: 100%

Auto Transformer: 25-64%

Wye-delta: 25-33%